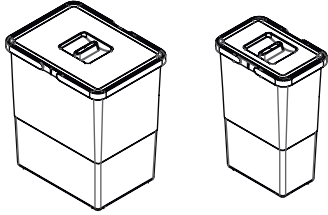
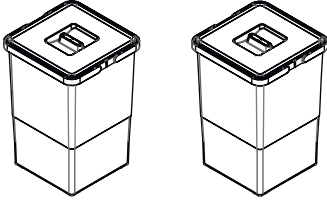
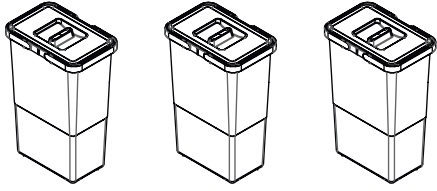
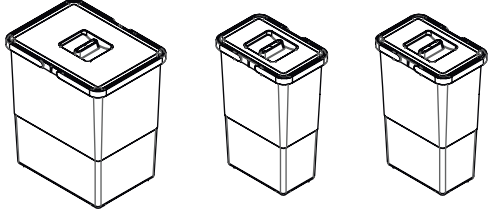
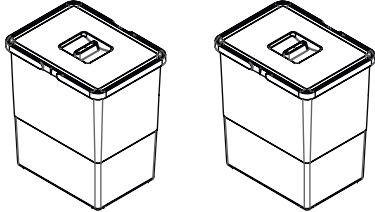
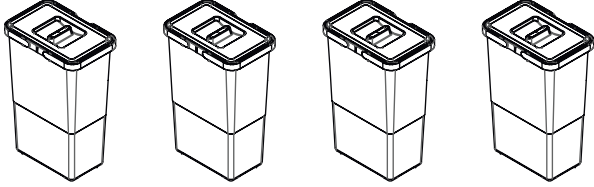
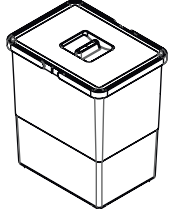
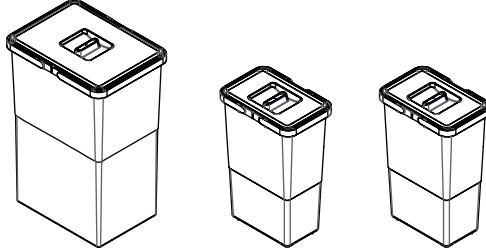
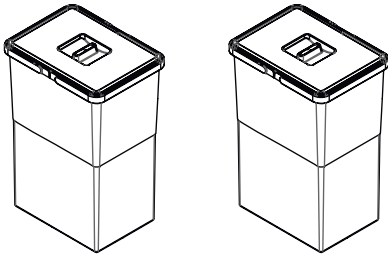
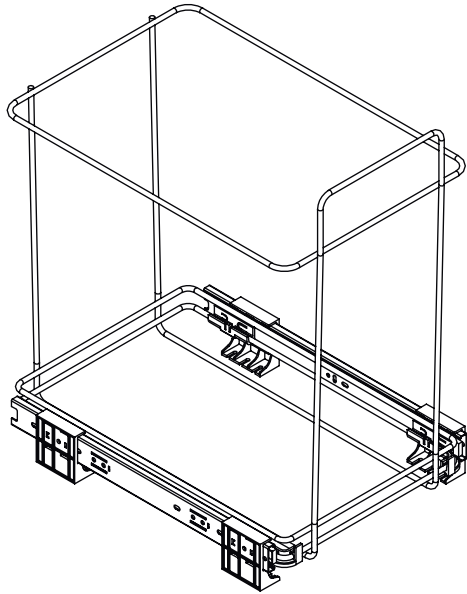
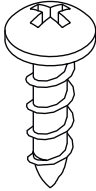
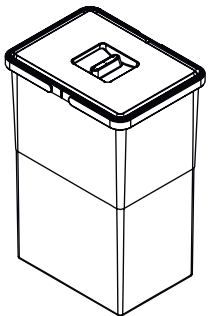

<p>PF01 34A1</p>  <p>18 L 8 L</p>	<p>PF01 34A2</p>  <p>12 L 12 L</p>
<p>PF01 34A3</p>  <p>8 L 8 L 8 L</p>	<p>PF01 34B1</p>  <p>18 L 8 L 8 L</p>
<p>PF01 34B2</p>  <p>18 L 18 L</p>	<p>PF01 34B3</p>  <p>8 L 8 L 8 L 8 L</p>
<p>PF01 34C1</p>  <p>18 L</p>	<p>PF01 44B1</p>  <p>24 L 8 L 8 L</p>
<p>PF01 44B2</p>  <p>24 L 24 L</p>	

نم الة
1 9 5 4

ECOFIL

COMPONENTS	
 <p>A (X1)</p>	 <p>B (X4)</p>
	 <p>C (variable for each model)</p>

1

Base Drilling Layout

Place the bin in correct position as indicated and fix the 2 frontal screw

PF01 34A : S1 = 200 mm , S2 = 290 mm

PF01 34B : S1 = 280 mm , S2 = 290 mm

PF01 34C : S1 = 200 mm , S2 = 190 mm

PF01 44B : S1 = 270 mm , S2 = 290 mm

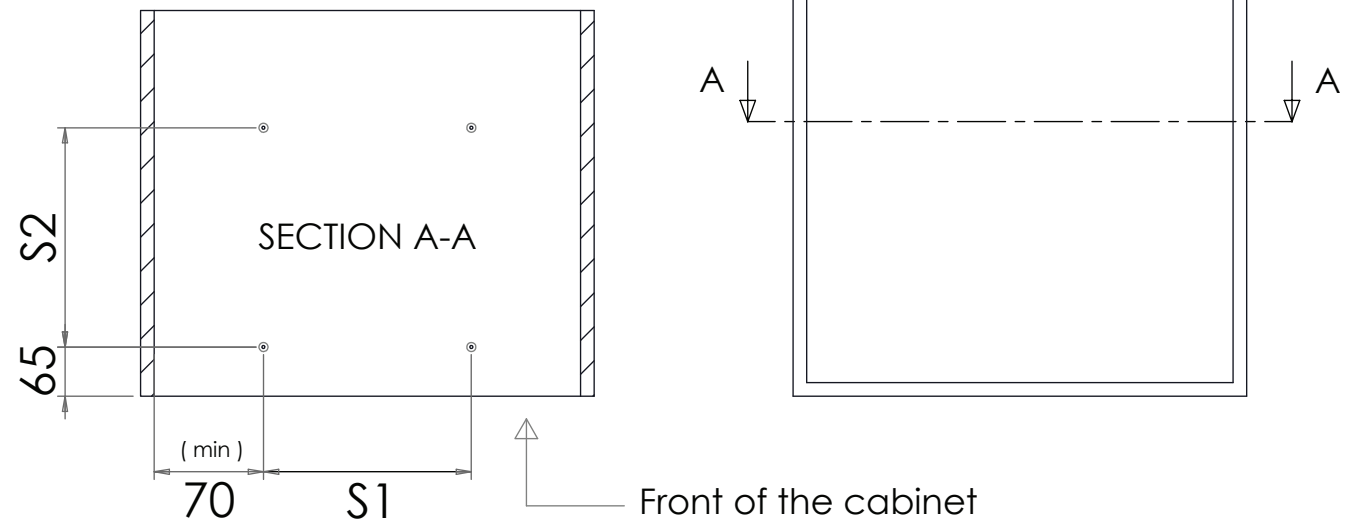

2

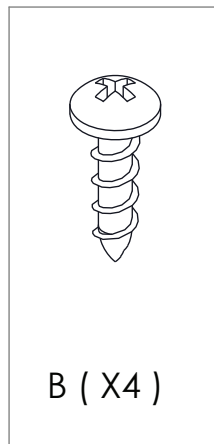
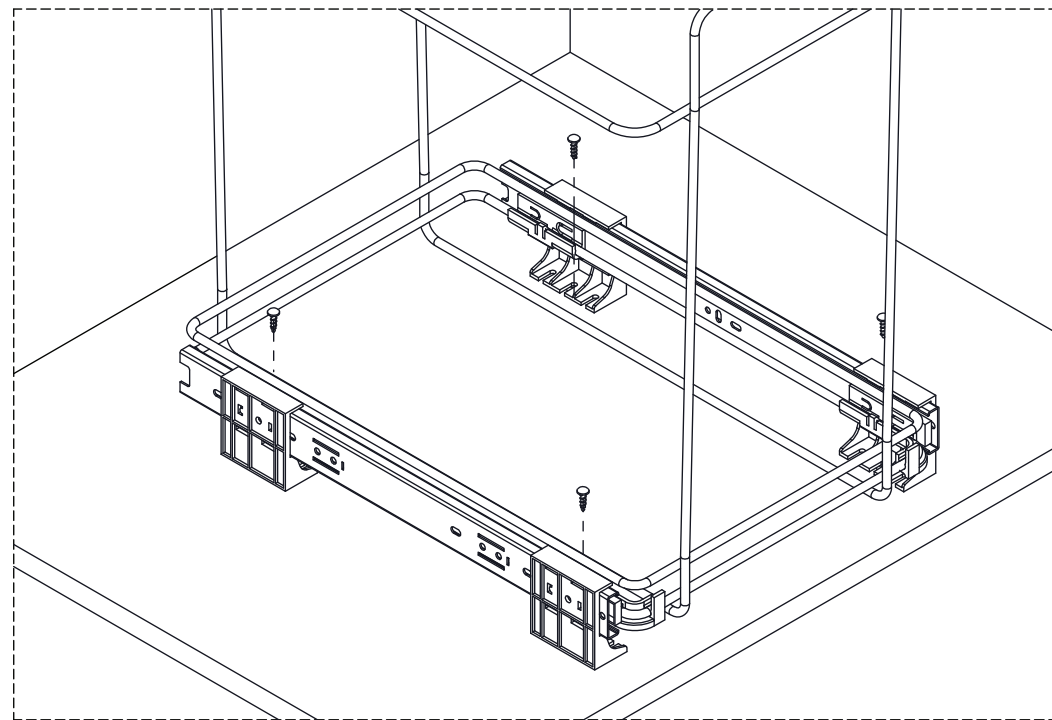

A (X1)

PF01 34A

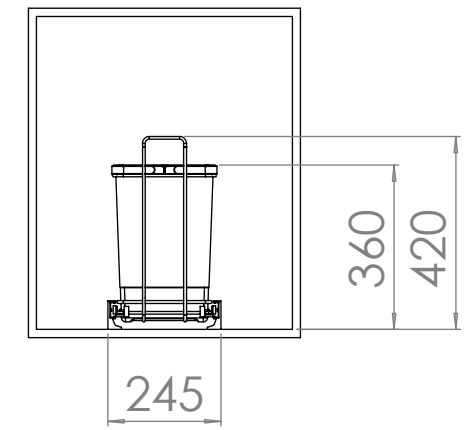
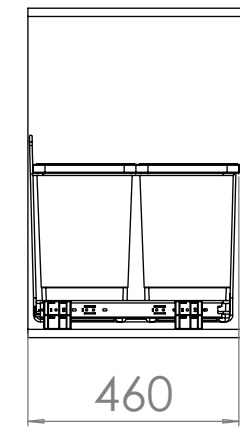
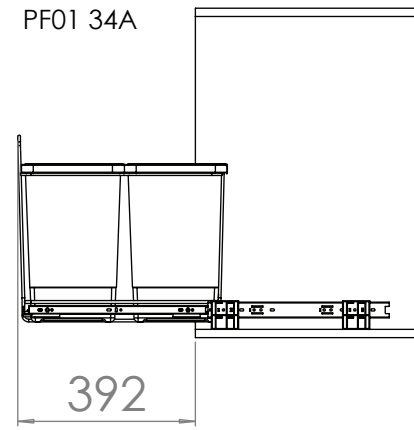

PF01 34B

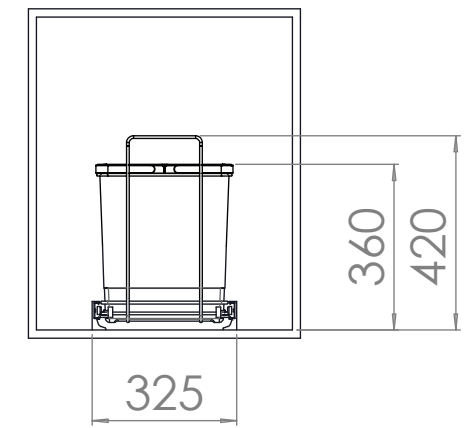
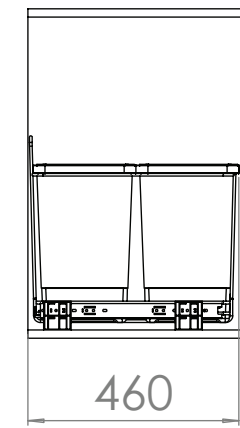
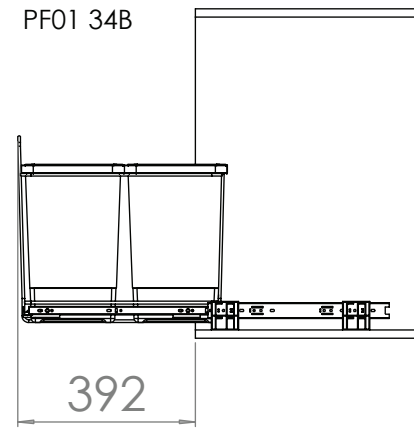

PF01 34C

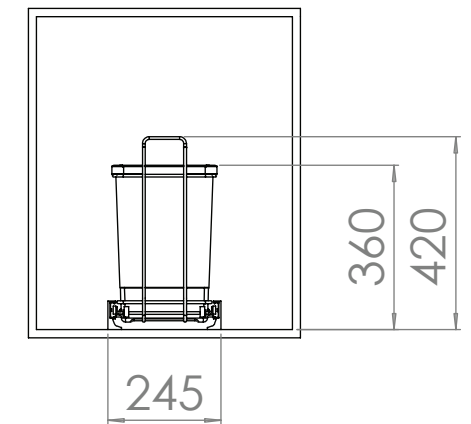
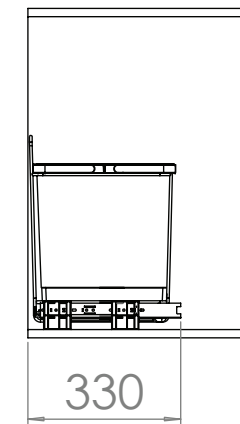
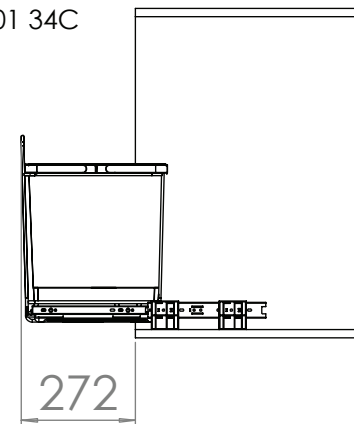

PF01 44B

